

GRAFICI DEFLESSIONI LINEA METAL GRECATA

DEFLESSIONE CAMPATA SINGOLA

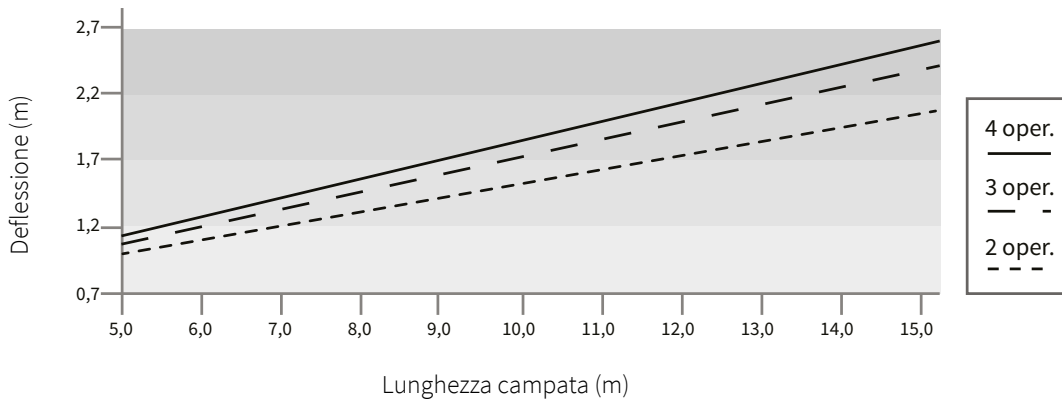

DEFLESSIONE CAMPATA MULTIPLA

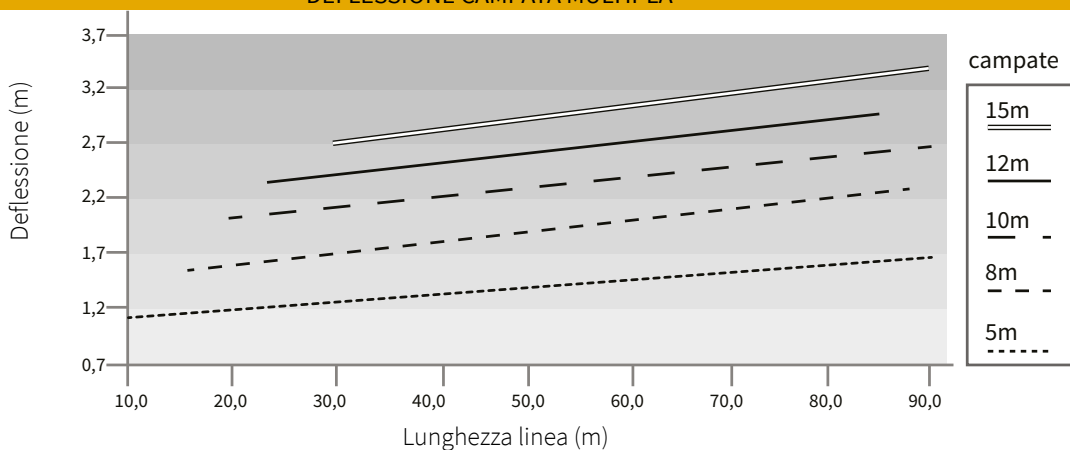



/ IDONEITÀ APPLICATIVA LAMIERA GRECATA

Caratteristiche lamiera				Passo massimo arcarecci			
Materiale	Spessore nominale [mm]	Altezza greca [mm]	Passo greche [mm]				
ACCIAIO 8 RIVETTI	0,50	20-21	75-80		■	■	■
		28	112		■ (2-op)	■	■
		40	200-250*				■
	0,60	20-21	75-80	■	■	■	■
		28	112		■	■	■
		40	250		■	■	■
	0,70	20-21	75-80	■	■	■	■
		28	112	■	■	■	■
		40	250	■	■	■	■
ALLUMINIO 10 RIVETTI	0,70	20-21	75-80		■ (2-op)	■ (2-op)	■ (2-op)
		28	112		■ (2-op)	■ (2-op)	■ (2-op)
		40	200-250			■ (2-op)	■ (2-op)
	0,80	20-21	75-80		■	■	■
		28	112		■	■	■
		40	200-250*		■	■	■

In caso di deviazione angolare consulta le eventuali restrizioni su www.livith.it

Per lamiere di tipologia differente da quelle elencate nella presente tabella contattare Livith S.p.A.

SCHEDA TECNICA

METAL GRECATA ESTREMITÀ

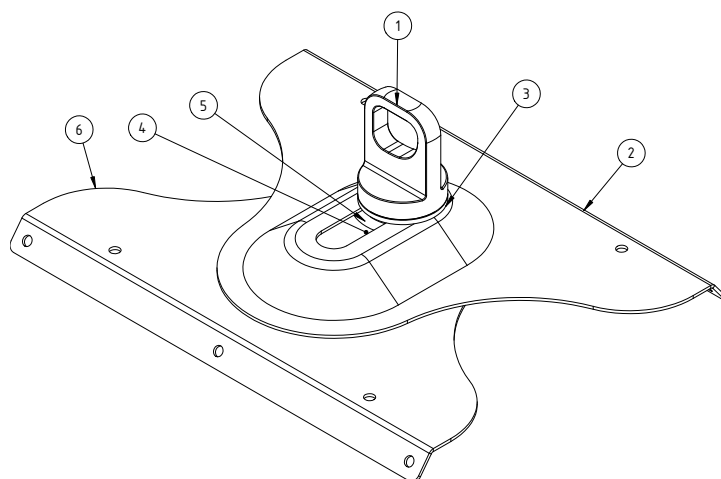
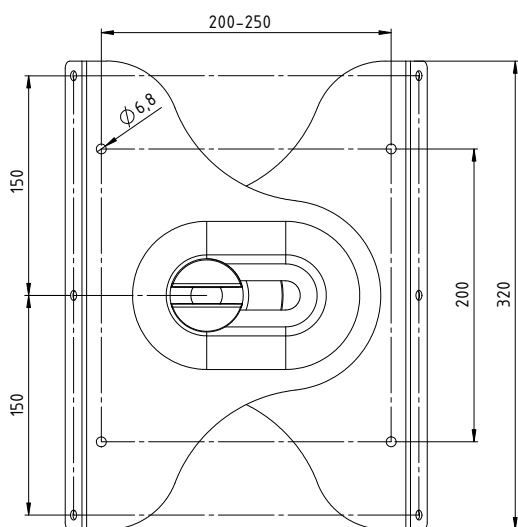
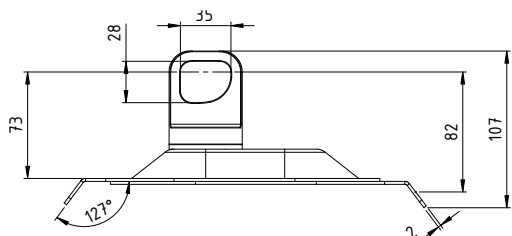

METAL GRECATA ESTREMITÀ

	PARTE	PESO (Kg)	MATERIALE	FINITURA	QUANTITÀ
①	Anello rotante	0.14	7075-T6 (SN)	-	1
②	Piastra superiore	0.73	AISI 304	-	1
③	Rondella Teflon	0.01	Teflon	-	1
④	Dado autobloccante serie bassa	0.004	M16 DIN 985	-	1
⑤	Rondella	0.04	50x3 M16 UNI 6593	-	1
⑥	Piastra inferiore	0.74	AISI 304	-	1

SCHEDA TECNICA

METAL GRECATA INTERMEDIO

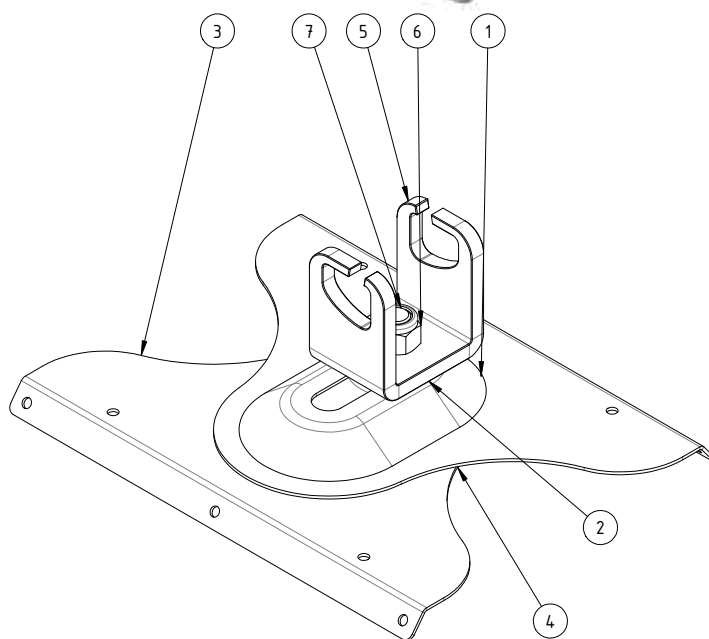
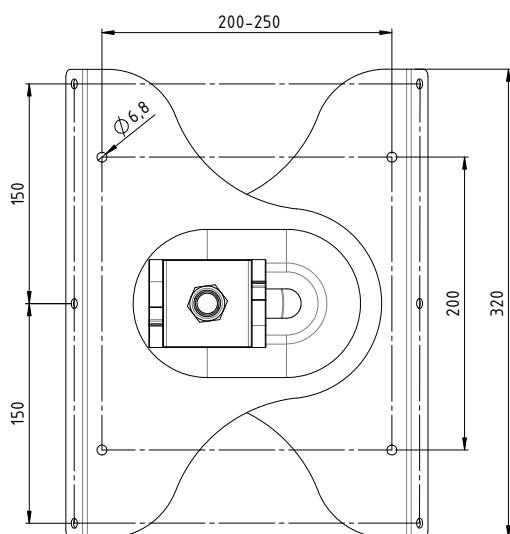
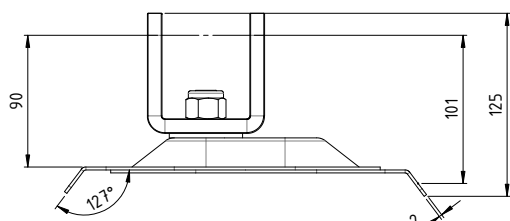

METAL GRECATA INTERMEDIO

	PARTE	PESO (Kg)	MATERIALE	FINITURA	QUANTITÀ
①	Piastra superiore	0.73	AISI 304	-	1
②	Rondella Teflon	0.01	Teflon	-	1
③	Piastra inferiore	0.74	AISI 304	-	1
④	Rondella	0.04	50x3 M16 UNI 6593	-	1
⑤	Anello intermedio	0.84	AISI 304	-	1
⑥	Dado autobloccante	0.006	ISO 7040-M16	-	1
⑦	Vite TC CE	0.014	UNI 5933 M16x40	-	1

SCHEDA TECNICA

KIT TENSIODISSIPATORE

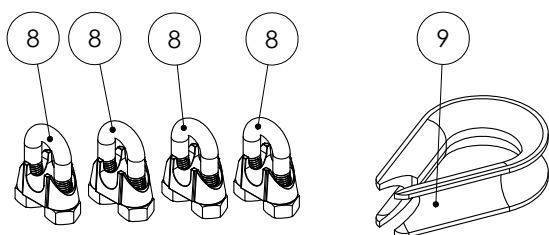
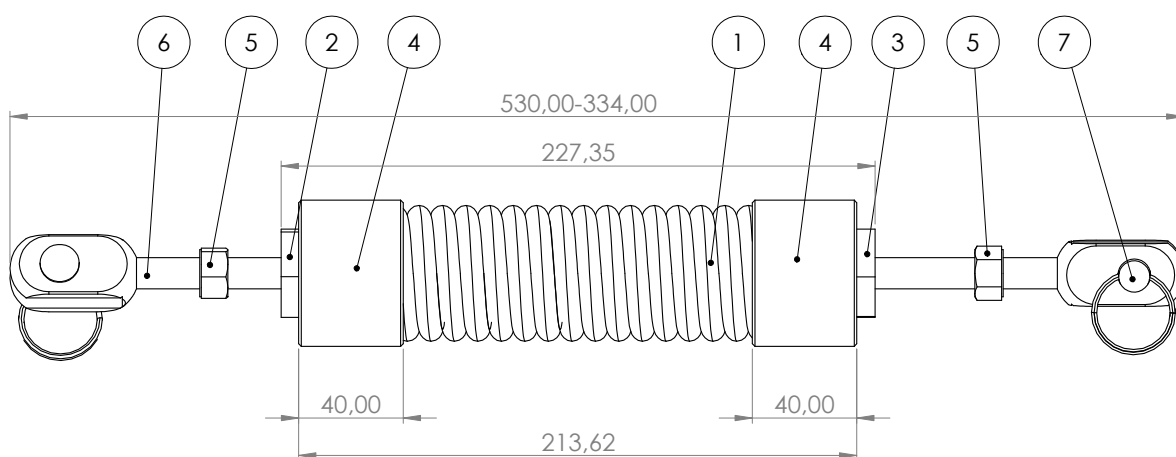

KIT TENSIODISSIPATORE

	PARTE	PESO (Kg)	MATERIALE	FINITURA	QUANTITÀ
①	Tensiodissipatore molla	1.62	AISI 304	-	1
②	Inserto DX	0.11	7075-T6 (SN)	-	1
③	Inserto SX	0.04	7075-T6 (SN)	-	1
④	Copritesta a pressare	0.11	AISI 304	-	2
⑤	ISO - 4032 - M12 - W	-	A2	-	2
⑥	Forcella DX e SX	0.14	AISI 304	-	2
⑦	Perno con coppiglia	0.05	AISI 304	-	2
⑧	Morsetto ad U	0.02	A2	-	4
⑨	Redance	0.03	AISI 304	-	1

SCHEDA TECNICA

KIT TENSIODISSIPATORE CON INDICATORE DI TENSIONE

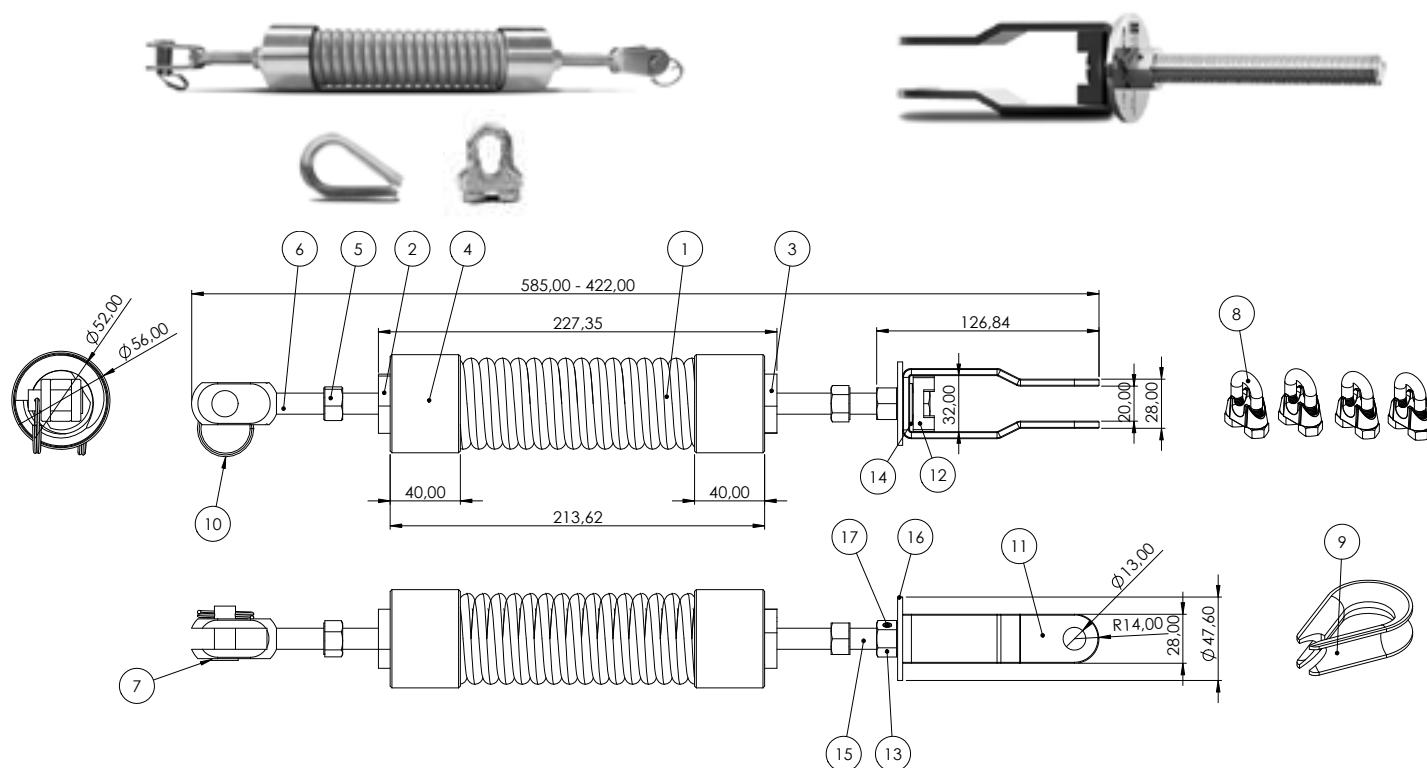

KIT TENSIODISSIPATORE CON INDICATORE DI TENSIONE

PARTE	PESO (Kg)	MATERIALE	FINITURA	QUANTITÀ
① Tensiodissipatore molla	1,62	AISI 304	-	1
② Tensiodissipatore inserto DX	0,11	7075-T6 (SN)	-	1
③ Tensiodissipatore inserto SX	0,11	7075-T6 (SN)	-	1
④ Tensiodissipatore copritesta a pressione	0,11	AISI 304	-	2
⑤ ISO-4032-M12-W-N	-	A2	-	2
⑥ KIT tensiodissipazione forcella DX e SX	0,14	AISI 304	-	1
⑦ Perno con coppiglia	0,05	AISI 304	-	1
⑧ Morsetto a U	0,02	A2	-	4
⑨ Redance	0,03	A2	-	1
⑪ Indicatore di tensione Piatto	0,21	AISI 304	-	1
⑫ Indicatore di tensione blocca bullone	0,01	ABS generico	-	1
⑬ ISO - 4033 - M12 - W - N	-	A2	-	1
⑭ Indicatore di tensione molla a tazza DIN 2093 23x12_2x1_5	-	1.8159 (51CrV4)	-	1
⑮ ISO 4017 - M12 x 120-C	-	A2	-	1
⑯ Indicatore di tensione rondella	0,04	AISI 304	-	1
⑰ ISO 4027 - M6 x 6-C	-	A2	-	1

SCHEDA TECNICA

FAST GRIP

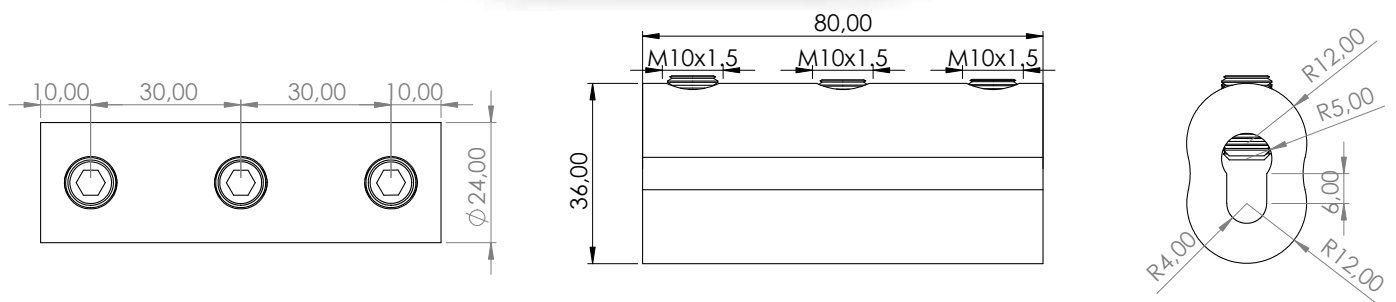

FAST GRIP

	PARTE	PESO (Kg)	MATERIALE	FINITURA	QUANTITÀ
①	Fast grip	0.12	6063-T6	-	1
②	ISO 4026-M10x16-S con frena-filetto	-	A2	-	3

SCHEDA TECNICA

SAFETY STOP

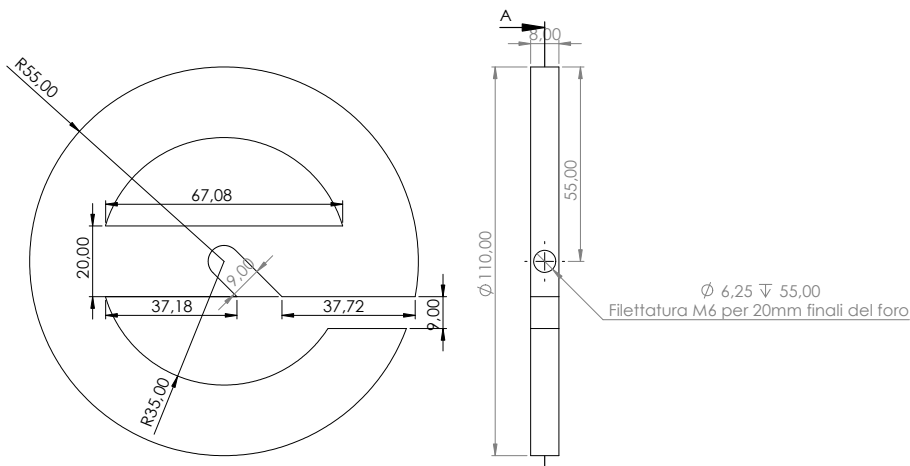

SAFETY STOP

	PARTE	PESO (Kg)	MATERIALE	FINITURA	QUANTITÀ
①	Safety stop	0.14	6063-T1	Satinatura burattata	1

SCHEDA TECNICA

FUNE

